



PERFORMANCE DATA SHEET

Meets or exceeds MEPS (Minimum Efficiency Performance Standards), as described by the US Department of Energy in docket 10CFR431 and Natural Resources Canada's Amendment 14

Catalogue #: MTR-202FDJH

HP	kW	Voltage	Frequency	EFF.	P.F.	Frame	Design	F.L. RPM
2	1,49	115 / 208 - 230	60Hz	83,0%	0,992	56JH	B	3510

FLA			Service Factor	N.L. Amps @ 115V	N.L. Amps @ 230V	KVA Code	L.R. Amps @ 15v	L.R. Amps @ 230v
115	208	230		1,15	2,45		1,225	H
15,92	8,8	7,96						

Start Cap.	Run Cap.	Main Winding Ω 115V @ 25°C	Main Winding Ω 230V @ 25°C	Auxillary Winding Ω @ 25°C	Safe Cold Start (Secs)
350 μ f/300vac	80 μ f/450vac	0,2100	0,850	0,690	12

Wgt. Lbs	PH	Duty	Insul. Class	Amb.	Elevation	Temp. Rise° C
40	1	Cont.	F	40°C	1000M (3,300 Ft)	42

% Efficiency		Power Factor		Torque		Protection
Full Load:	83,0%	Full Load:	0,99	Full Load Ft/Lbs	3,0	
3/4 Load:	73,4%	3/4 Load:	0,96	Locked Rotor %	273	
1/2 Load:	54,3%	1/2 Load:	0,94	Break Down %	301	

Rotor Inertia Wk2 Lb-Ft2	Max Load Inertia Wk2 Lb-Ft2	Shaft Material	Frame Material	DE Bracket Type	ODE Bracket Type	Enclosure	NEMA Rating	Lead Wire Size
/	/	304SS	Rolled Steel	Aluminium Alloy		TEFC	IP55	/

Ball Bearings		Grease	Mount Type	Orientation	Paint	Sound Pressure @ 3FT	Sound Power
DE	ODE						
6205	6203	Sealed Bearings	Rigid	Horizontal	Black	72	/

WIRING CONNECTION DIAGRAM : B

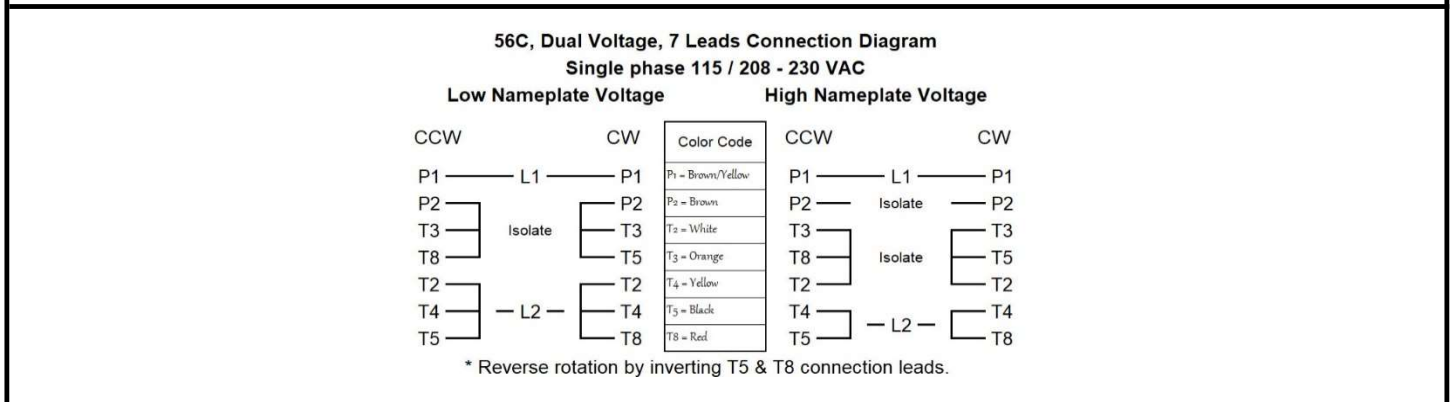



Date: 2023-12-22
 Customer: _____
 Contact: _____
 Submittee: J.C. Lavallée

Catalogue #: **MTR-202FDJH**

Meets or exceeds MEPS (Minimum Efficiency Performance Standards), as described by the US Department of Energy in docket 10CFR431 and Natural Resources Canada's Amendment 14

HP	VAC	RPM	Enclosure	Frame	Frequency	Design	Poles	LR Code Letter	Insulation Class	Temp. Rise °C
2	230	3510	TEFC	56JH	60	B	2	H	F	42

Load %	0%	25%	50%	75%	100%	125%	150%
Amps	#N/A	#N/A	#N/A	#N/A	#N/A	#N/A	#N/A
Torq ft/lbs	0	#N/A	#N/A	#N/A	#N/A	#N/A	#N/A
RPM	0	#N/A	#N/A	#N/A	#N/A	#N/A	#N/A
Eff	0	#N/A	#N/A	#N/A	#N/A	#N/A	#N/A
PF	0,00	#N/A	#N/A	#N/A	#N/A	#N/A	#N/A

	Locked Rotor	Pull-Up	Breakdown	Rated Load	Idle	Duty	S. F.	Ambient	Elevation	dBa @ 1M
Speed (RPM)	0	1800	2880	3510	3600	Continuous	1,15	40°C	3,300 ft	72
Current (Amps)	58	49,3	34,5	#N/A	#N/A	VFD Rating: Meets MG1 parts 31.4.4.2				
Torque (ft-lbs)	#N/A	#N/A	#N/A	#N/A	0,0	C.T.	0,85	V.T.	0,69	

